

--	--	--	--	--

Name

Present School

The London Independent Girls' Schools Consortium

Group 1

Mathematics Entrance Examination

9th January 2009

Time allowed: 1 hour 15 minutes

Write in pencil.

Do all your rough working in the space near the question. Do not rub it out.

If you cannot answer a question go on to the next one.

CALCULATORS AND RULERS ARE NOT ALLOWED.

1.
$$\begin{array}{r} 24153 \\ + 3274 \\ \hline \end{array}$$

2.
$$\begin{array}{r} 5137 \\ \times 8 \\ \hline \end{array}$$

3.
$$4 \overline{)3256}$$

4. Find the difference between 2.7 metres and 32 centimetres.

Give your answer in metres.

Answer:

5. What fraction of a minute is 40 seconds?

Answer:

6. Put the following fractions in order, starting with the smallest.

$$\frac{2}{3}, \frac{3}{5}, \frac{29}{45}$$

Answer:



7. Which is the smallest number?

0.54 0.092 0.635 0.3

Answer:

8. Which number between 55 and 65 can be divided exactly by 9?

Answer:

9. Which number between 140 and 170 can be divided exactly by both 8 and 9?

Answer:

10. Add together the following numbers and write your answer in figures.

nine million eleven thousand twelve hundred thirteen

Answer:



11. The diagram shows the distances between some cities.



If the total distance travelled from Lisbon to Munich is 2730 km, how far was the journey from Madrid to Paris?

Answer:km

12. Sonal wishes to buy a magazine priced at £2.28.

a. What is the least number of coins she could use to reach the exact price?

Answer:

b. Miriam pays for two of these magazines with a £10 note. How much change should she receive?

Answer: £.....

13. a. Complete the table of values for this number machine with the rule 'multiply by 4, then subtract 3'.

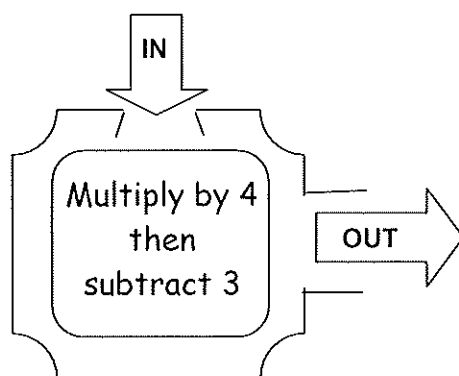

Number IN	Number OUT
7	25
2	5
10	
	81



- b. What is the rule for this number machine? Write your answer inside the machine.

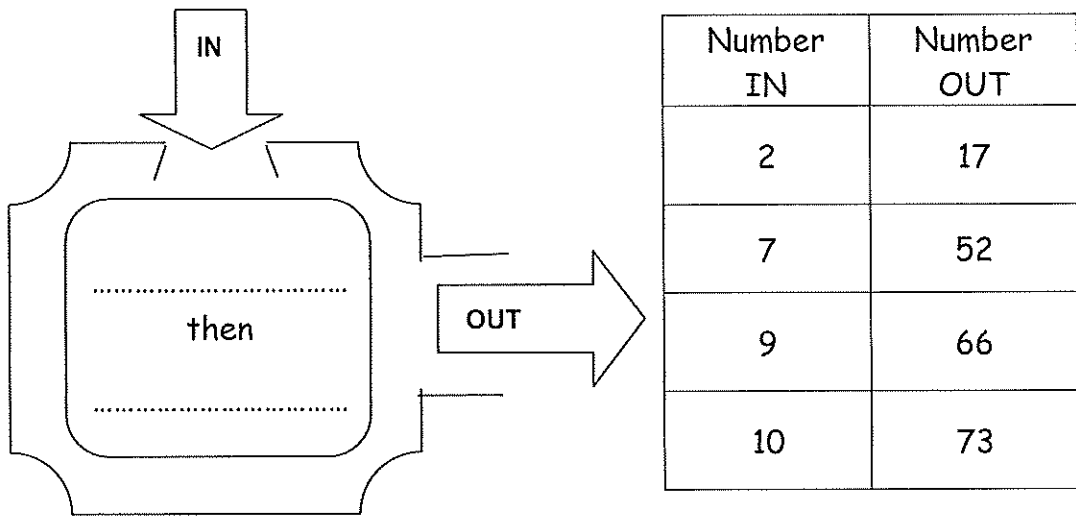

14. On her birthday last year, Emily was 140cm tall. When she measured herself on her birthday today, she calculated that she had grown by a fifth of the height she was a year ago.

- a. How tall is she now?

Answer:cm

- b. Emily's brother, Jack, is now 105cm tall, having grown by one sixth of his height a year ago. How tall was Jack one year ago?

Answer:cm



15. 32 students and 4 members of staff from Encrypt School are going to a lecture on code-breaking.

Code-Breaking Lecture

Ticket Prices

Students: £14.00 each
Adults: £15.00 each

1 free adult ticket provided with every 10 student tickets purchased

How much will the tickets cost in total for the school party?

Answer: £.....

16. The scale is measured in degrees Celsius, °C.

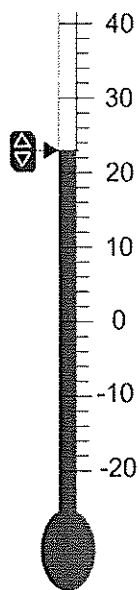

- a. What temperature does the thermometer show?

Answer: °C



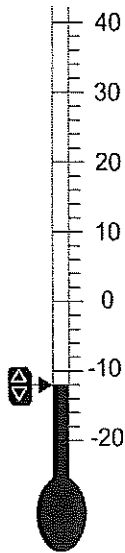

b. What temperature does this thermometer show?

Answer: °C

c. What is the difference between these two temperatures in °C?

Answer: °C

d. A flow chart for converting °C into degrees Fahrenheit, °F, is

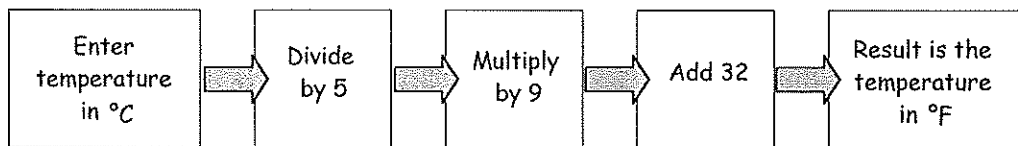

i. What temperature is 20 °C in °F?

Answer: °F

ii. What temperature is 59 °F in °C?

Answer: °C



17. The time in Athens is two hours ahead of the time in London. For example when it is 15:00 in London it is 17:00 in Athens.

- a. Nani flies directly to Athens from London, departing at 08:20 hours. If the journey from London takes 3 hours 45 minutes, at what time, local to Athens, will Nani arrive in Athens?

Answer:

- b. It takes the same time to fly from Athens to London as it takes from London to Athens.

Nani leaves Athens airport at 19:15 hours.

At what time will she reach London (local time)?

Answer:



18. The graph shows how a freshly made cup of tea cools over time.

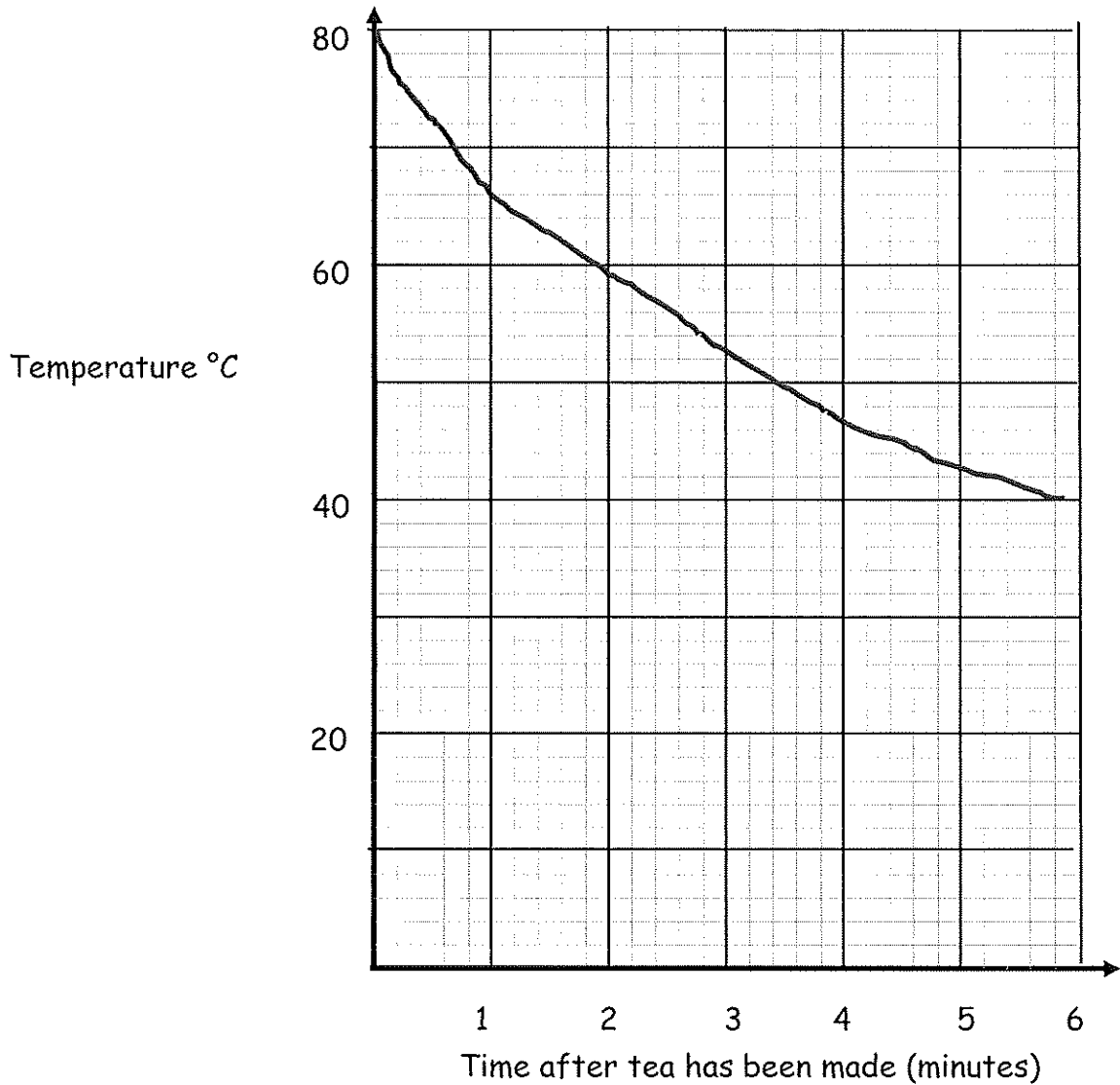

a. What is the temperature of the tea 1 minute after it has been made?

Answer: °C

b. After how many minutes and seconds has the tea's temperature cooled to 45°C?

Answer: mins secs



- c. How long does it take for the tea to halve its original temperature?
Give your answer in minutes and seconds.

Answer: mins secs

- d. What is the temperature of the tea 3 minutes 48 seconds after it was made?

Answer: °C



19. How many triangles are there in this diagram?

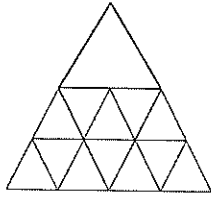

Answer:

20. What is the area of this shape?

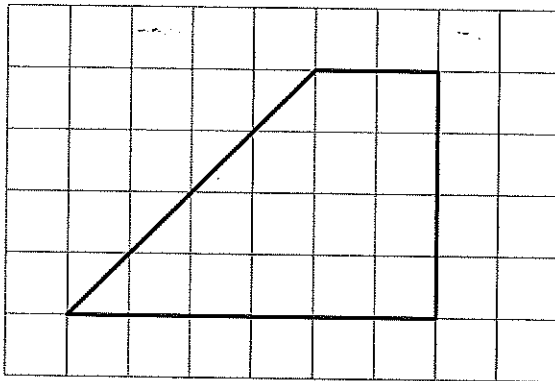

Answer: units²

21.

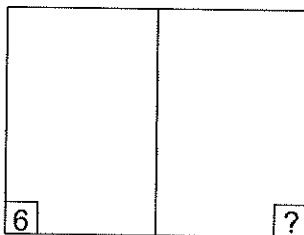

This is a loose sheet from a newspaper with 64 pages. What is the missing page number?

Answer:



22.

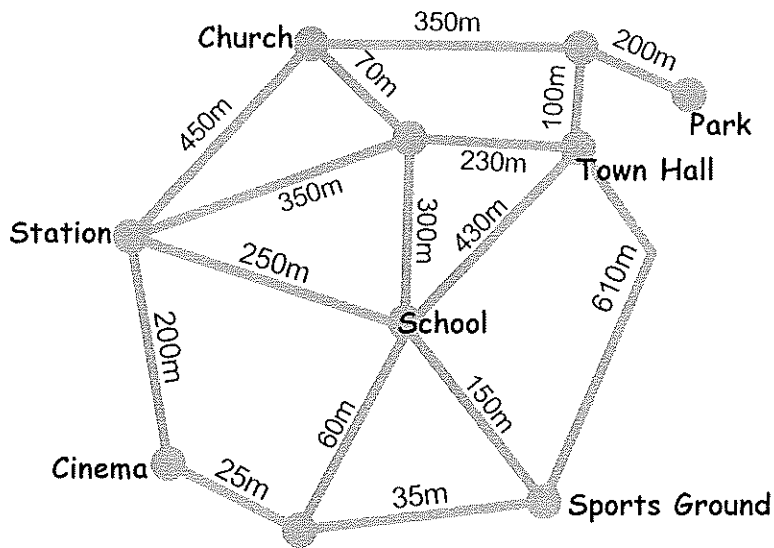
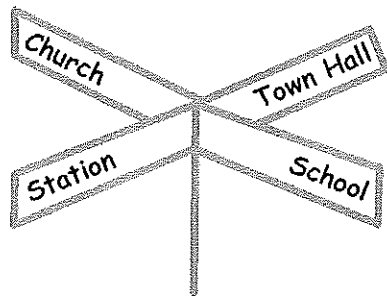

Diagram not drawn to scale.

- a. Put a cross on the map where this signpost should go.



- b. Using the map above what is the shortest route from the park to the cinema?

Answer:m

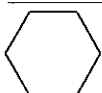

23. It takes me half an hour to fill the paddling pool to a depth of 20cm using one hose.

a. How long will it take to fill it to the same depth if I use two hoses?

Answer:

b. How long will it take to fill it to a depth of 30cm if I use 3 hoses?

Answer:

24. 72 pupils were asked to choose their favourite type of film. The results are shown in the diagram.

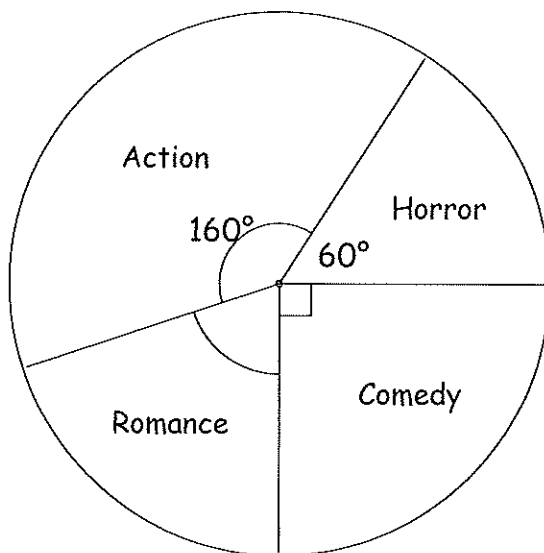

a. How many pupils chose Comedy?

Answer:

b. What angle should be in the sector representing Romance?

Answer:



25. What fraction of this diagram is shaded?

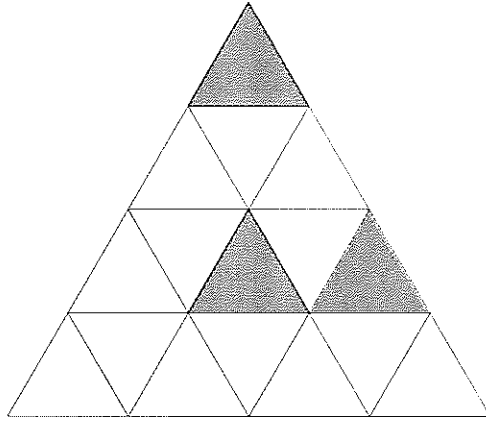

Answer:

26. Shade $\frac{3}{8}$ of this diagram.

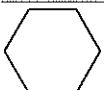
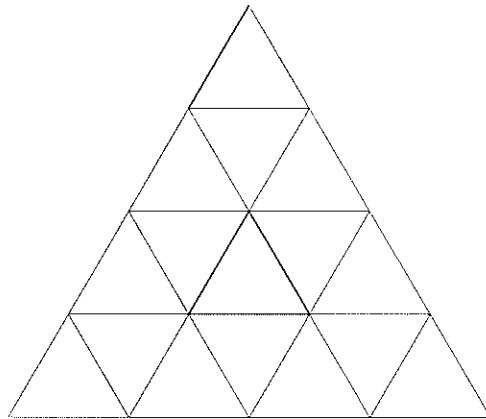

27. Fred is facing south. He turns through 45° in a clockwise direction.

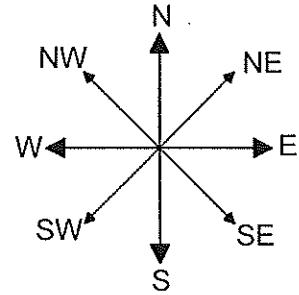

a. Which direction is Fred now facing?

Answer:

b. Johnny is facing west. How many degrees would he need to turn, clockwise, to face north east?

Answer:

c. What is the size of the reflex angle between NE and W?

Answer:

d. Sandra is facing N and turns clockwise through 495° . In which direction is she now facing?

Answer:



28.

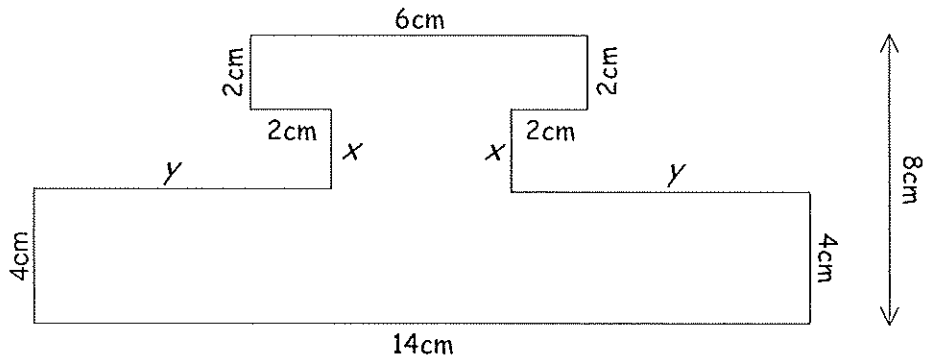

a. What are the values of x and y ?

Answer: $x = \dots\dots\dots$ cm

Answer: $y = \dots\dots\dots$ cm

b. What is the perimeter of the shape?

Answer: $\dots\dots\dots$ cm

c. What is the area of the shape?

Answer: $\dots\dots\dots$ cm²



29. A ship is being tracked by a satellite.

a. Plot the following points on the grid below to show the position of the ship at different times.

3pm (1,4)

4pm (1,8)

5pm (6,8)

6pm (6,5)

7pm (1,4)

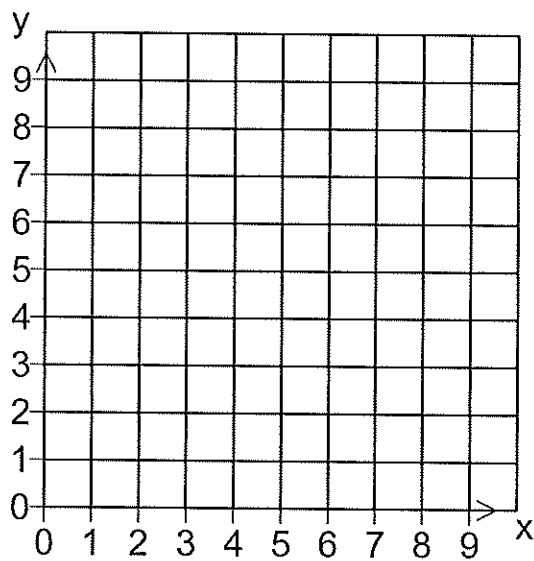

b. Join the points in order. What is the name of the shape you have drawn?

Answer:



30. Here are three patterns.

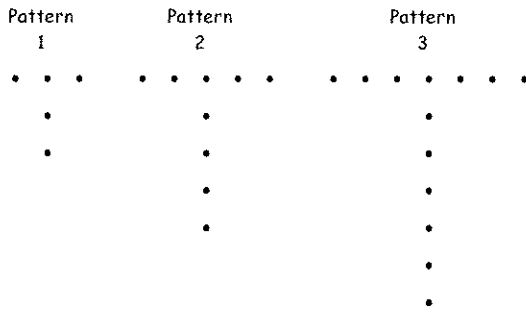

a. Choose the next pattern in the sequence. Tick the correct box.

Pattern 4	
• • • • • • • • • • • • • • •	
• • • • • • • • • • • • • • • • •	
• • • • • • • • • • • • • • • • •	

b. Complete the table

Pattern Number	1	2	3	4	5
Number of Dots	5	9	13		

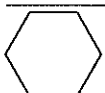

31. Nine identical squares are glued together to form the figure.

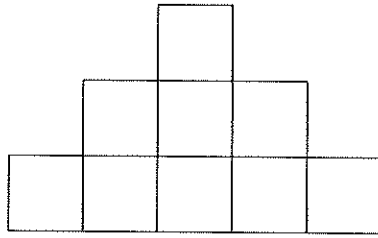

The perimeter of the figure is 160cm.

- a. Find the length of the side of each small square.

Answer:cm

- b. Find the area of each small square.

Answer:cm²

- c. Find the area of the whole figure.

Answer: cm²

32. Amir, Anna and Arjun have bought some fruit at a market stall.

Amir bought 2 Pears and 1 Mango for £1.35

Anna bought 1 Pear and 2 Mangos for £1.20

Arjun bought 1 Pear, 1 Mango and 1 Apple for £1

How much, in pence, did the apple cost?

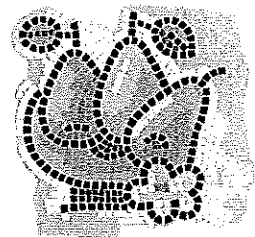

Answer:p

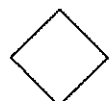

33. 72 ladies attending a garden party were each wearing a pair of gloves. Some ladies lost their gloves. The ratio of ladies who lost gloves to the ladies who did not lose any gloves was 5:13.

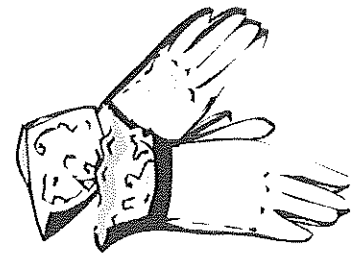

- a. What fraction of ladies lost their gloves?

Answer:

52 ladies did not lose their gloves.
Some ladies lost one glove and some lost both gloves.
After the party, the 29 missing gloves were found.

- b. How many ladies lost only one glove?

Answer:

-
34. Dominic, Hannah and Abdul have 36 sweets between them.
Dominic has half as many sweets as Hannah.
Abdul has 3 times as many sweets as Hannah.

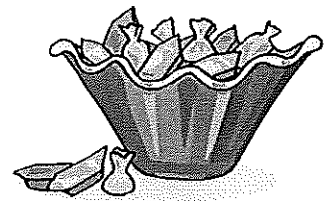

How many sweets does Abdul have?

Answer:

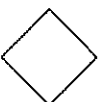

35. If a and b are numbers, then $a \heartsuit b$ means 'multiply a by itself and then subtract b '.

For example

$$\begin{aligned} 2 \heartsuit 3 &= 2 \times 2 - 3 \\ &= 4 - 3 \\ &= 1 \end{aligned}$$

- a. Calculate $3 \heartsuit 4$

Answer:

- b. Find a when $a \heartsuit 4 = 32$

Answer:

- c. Find x when $x \heartsuit x = 72$

Answer:

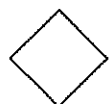

36. Each letter from A to I is a code for one of the digits 1, 2, 3, 4, 5, 6, 7, 8 or 9.
 We already know that $H = 2$ and $I = 7$
 $H + I = 9$
 $H \times I = 14$
 and HI means 27

Now crack the rest of the code using the following:

$G \times C = 30$	$E + E = BA$
$D + D = A$	$E \times E = AB$
$D \times D = BC$	$D \times E = FC$
$D + E = BF$	

Answers $A = \dots, B = \dots, C = \dots, D = \dots, E = \dots, F = \dots, G = \dots$

37. Jessica arranges numbers in rows to get a triangular arrangement.
 The first four rows are shown below.

Row <u>1</u>								1
Row <u>2</u>				2	3	4		
Row <u>3</u>			5	6	7	8	9	
Row <u>4</u>	10	11	12	13	14	15	16	

- a. What is the last number in row 12?

Answer:

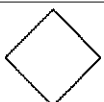

b. How many numbers are there in the 20th row?

Answer:

c. In which row are there 21 numbers?

Answer:

d. Jessica works out the mean (average) of the numbers in each row.

Row	1	2	3	4
Mean	1	3	7	13

What is the mean of the numbers in row 10?

Answer:

e. What is the sum of numbers in the 8th row?

Answer:

End of Paper

